

# SPECIFICATION SUBMITTAL SHEET



## BACKWATER VALVES

**Job Name:** \_\_\_\_\_  
**Job Location:** \_\_\_\_\_  
**Engineer:** \_\_\_\_\_  
**Approval:** \_\_\_\_\_

**Contractor:** \_\_\_\_\_  
**Approval:** \_\_\_\_\_  
**Contractor's PO#:** \_\_\_\_\_  
**Representative:** \_\_\_\_\_

**SPECIFICATIONS:**

- Designed to protect low areas or basements from the backflow of waste from the street sewers
- Available in 3", 4", and 6" Hub outlets
- Fits 3", 4" and 6" DVW pipe
- Complies with ASME A112.14.1
- Cap with O-Ring screws directly in to Backwater valve
- Available with 16" Riser and Snap-on cover

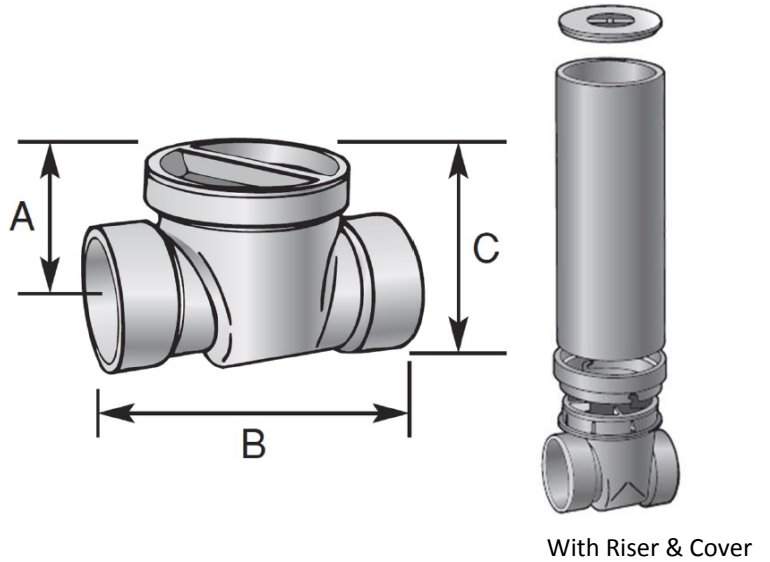

Qty	Product Code	Description	Model #	A	B	C	Riser Diameter	Drop Dimension	Case Qty
<b>BACKWATER VALVES</b>									
	86210	3" PVC Backwater Valve	BWV3P	3.51"	7.56"	6.10"	6"	0.640"	4
	86215	3" ABS Backwater Valve	BWV3A	3.51"	7.56"	6.10"	6"	0.640"	4
	86220	4" PVC Backwater Valve	BWV4P	4.47"	11.18"	7.18"	8"	0.742"	2
	86225	4" ABS Backwater Valve	BWV4A	4.47"	11.18"	7.18"	8"	0.742"	2
	86235	6" PVC Backwater Valve	BWV6P	5.5"	15.25"	9.90"	10"	0.629"	1
	86236	6" ABS Backwater Valve	BWV6A	5.5"	15.25"	9.90"	10"	0.629"	1
<b>BACKWATER VALVES WITH RISER AND COVER</b>									
	86211	3" PVC Backwater Valve w/Riser & Cover	BWV3PAS	3.51"	7.56"	6.10"	6"	0.640"	1
	86216	3" ABS Backwater Valve w/Riser & Cover	BWV3AS	3.51"	7.56"	6.10"	6"	0.640"	1
	86221	4" PVC Backwater Valve w/Riser & Cover	BWV4PAS	4.47"	11.18"	7.18"	8"	0.742"	1
	86226	4" ABS Backwater Valve w/Riser & Cover	BWV4AS	4.47"	11.18"	7.18"	8"	0.742"	1

