

FRM12 Metal Fire Resistant Washer Box Using Plastic Piping

Ratings: ASTM-E814 - 1 Hour (F), 1 Hour (T)
CAN/ULC - S115 1 Hour (F/FH), 1 Hour (FT/FTH)
ASTM-E814 - 2 Hour (F), 72 Min (T)
Firestop Device, Design No. IPS/PV 120-02

Models 82567 to 82599

1. Wall Construction

- Wood Or Steel Stud
- 1 Hour firewall construction consisting of each stud face being finished with 5/8 gypsum
- 2 Hour firewall construction consisting of each stud face being finished with 2 layers of 5/8 gypsum

2. Box Mounting

- Box should be securely fastened to stud with screws or nails
- Box units cannot be installed back to back within the same wall cavity

3. Piping Options

- Drains may be nominal 2" or larger PVC, ABS or metallic pipe
- Supply tubing may be either metallic or plastic
- All plumbing within the wall must be secured

4. Valve Options

- Single Lever with or without hammer arresters
- Quarter turn valves with or without hammer arresters

5. Intumescent Pad

- The IPS FR12M Series Plastic Washer Box is manufactured from special flame resistant resin. It has 2 factory installed intumescent pads (do not remove).
- Gaps between the box and the gypsum may be filled up to 1/2" with dry wall plaster.



Intertek
Control No. 5006851

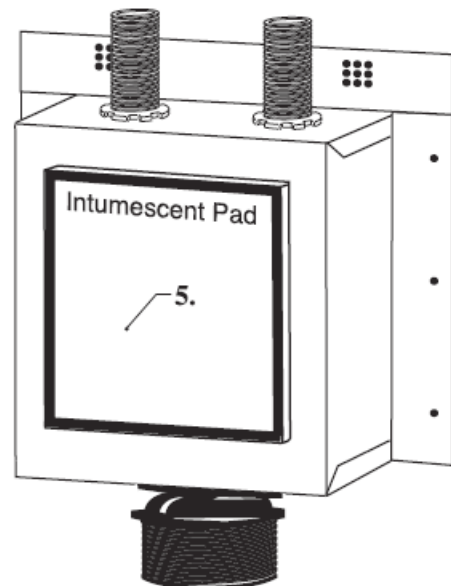
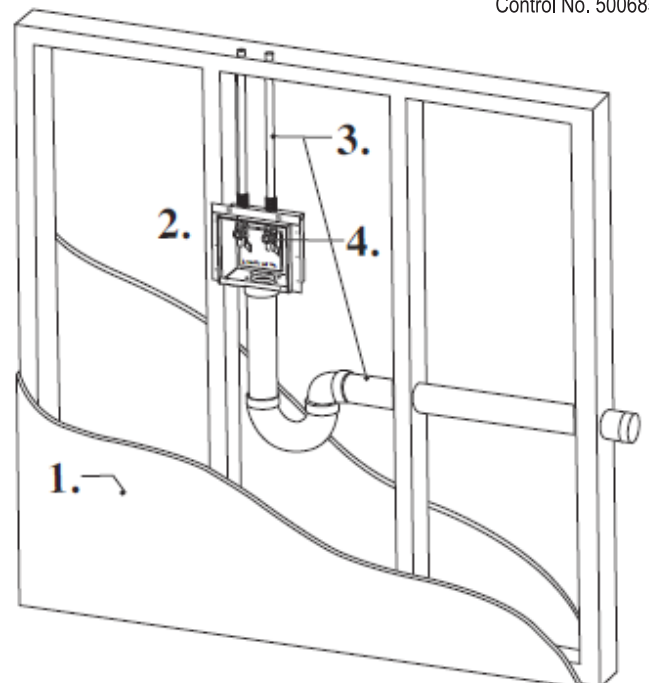

IPS
CORPORATION

500 Distribution Parkway, Collierville, TN 38017 ▪ Phone: 800-888-8312 ▪ Fax: 901-853-5008 ▪ www.ipscorp.com