

FLOODSTOP®

IPS CORPORATION

STOP FLOOD DAMAGE BEFORE IT EVER STARTS™

Pre-Plumbed Sewage Pump System - 45 Gal.

4/10 & 1/2 HP



System Includes

- 4/10 HP or 1/2 HP cast iron sewage pump with non-clog vortex impeller, tethered float and piggyback plug
- Polyethylene structural foam sewage basin (24 x 24 in. / 45 gal.)
- Polyethylene structural foam sewage cover (2 in. threaded discharge flange, 3 in. threaded vent flange, 6 in. access opening and 2-hole cord grommet)
- 2 in. silent check valve
- 4 in. water-tight inlet hub with stainless steel clamp (Fits 4 in. DWV Schedule 40/80 pipe)

This Pre-Plumbed Sewage Pump System is fully plumbed and ready to install. Included in the system is a sewage pump, sewage pump basin and basin cover, check valve and inlet hub.

The interior plumbing uses heavy duty schedule 80 PVC pipe and the discharge pipe quickly connects to the cover via a specifically designed threaded socket flange.

Use this system to install a bathroom in a new or existing home.

Basin Dimensions

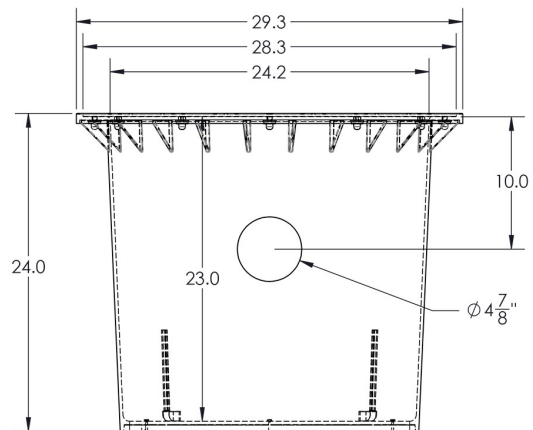

PRODUCT	DESCRIPTION	MODEL
22500	Pre-Plumbed Sewage System, 45 Gal, 1/2HP Tethered Float Switch, 20' cords	FSSW50T20B45
22501	Pre-Plumbed Sewage System, 45 Gal, 4/10HP Tethered Float Switch, 20' cords	FSSW40T20B45